

Enquiry Form

Heat Transfer Station Steam/Water



Please fill in this form as thoroughly and accurately as possible so that we can provide you with a suitable quotation promptly. Many thanks.

Enquiry date	
Quote date	

1. Sender

Company	
Address	
Contact	
Email	
Telephone	
Project name	
Location	



2. What type of system is required?

<input type="checkbox"/> Heating (HZG)	<input type="checkbox"/> Hot water (WWB)
--	--

Do you have any special technical connection requirements?

<input type="checkbox"/> Yes (please supply with enquiry)	<input type="checkbox"/> No
---	-----------------------------

3. What temperatures are to be expected on the primary and secondary sides? What is the required heating capacity?

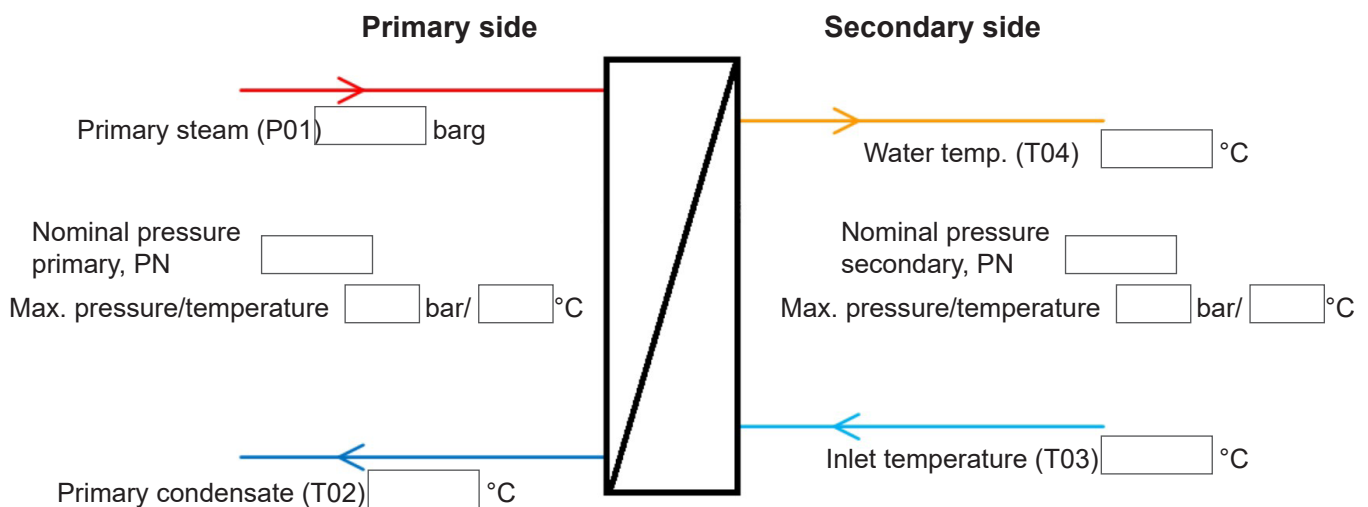

AF_StationDampfMessser_03_EN_MJ_0820

Enquiry Form

Heat Transfer Station Steam/Water



3a. Further data primary side

Capacity in kW			
Steam pressure in barg			
Condensate back press. in barg			
Tube bundle material	Steel	Copper	Stainless steel

3b. Further data secondary side

Secondary heating	
-------------------	--

3c. Control system

Actuators	electric	pneumatic
With controller?	yes	no
Power supply and control system if control is provided on site	230 V	
	115 V	3-point-step
	24 V	continuous

4. Conditions on site

Primary connection	from left	from right
To be dismantled for transport/access? (Reassembly not included)	yes	no
Maximum dimensions (access and height restrictions, stairs, lifts etc.)	B x H x T (mm)	

5a. Baelz Standard Configuration

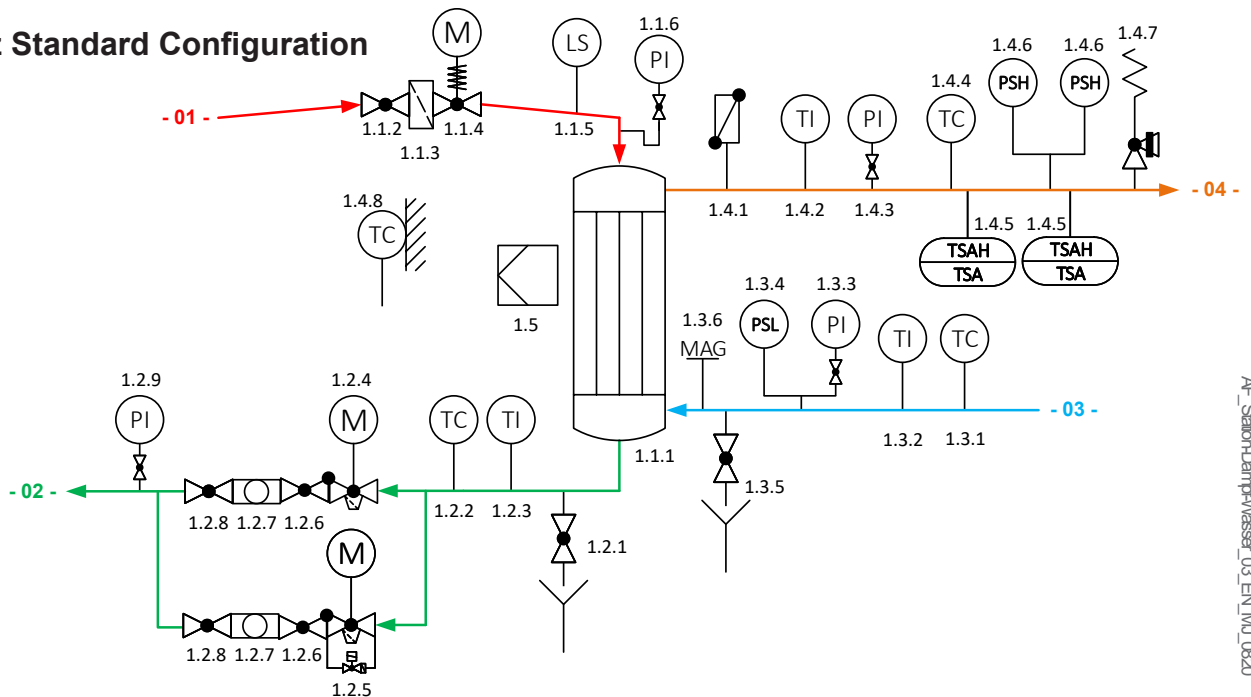

AF_StationDampfMessser_03_EN_I_MJ_0820

Technical specifications subject to change without notice

Copyright according to ISO 16016

Enquiry Form

Heat Transfer Station Steam/Water



5b. Key to components

		Position	#	Description
Primary side	01	Steam side	1.1.1	Heat exchanger
			1.1.2	Manual shut-off valve
			1.1.3	Strainer
			1.1.4	Valve with fail-safe function
			1.1.5	Level probe
			1.1.6	Manometer
	02	Condensate side	1.2.1	Ball valve for filling and emptying
			1.2.2	Immersion temperature sensor
			1.2.3	Thermometer
			1.2.4	Condensate control valve
			1.2.5	Condensate control valve with minimum load valve
			1.2.6	Check valve
			1.2.7	Inspection glass
			1.2.8	Manual shut-off valve
Secondary side	03	Return line	1.2.9	Manometer
			1.3.1	Immersion temperature sensor
			1.3.2	Thermometer
			1.3.3	Manometer
			1.3.4	Minimum pressure limiter
			1.3.5	Ball valve for filling and emptying
	04	Supply line	1.3.6	Connection for diaphragm expansion vessel (not in scope)
			1.4.1	Bleed valve
			1.4.2	Thermometer
			1.4.3	Manometer
			1.4.4	Immersion temperature sensor
			1.4.5	Safety temperature monitor and limiter
			1.4.6	Maximum pressure limiter
			1.4.7	Membrane safety valve
		Other	1.4.8	External temperature sensor
			1.5	Control cabinet and controllers

6. Further remarks or special requests eg. variations on the Baelz standard configuration

AF_StationDampfWasser_03_EN_1.11.0820